



# Mini-Cat® User's Manual

## VGA-over-UTP Video Transmission Systems

<p><b>UV1-S</b> Mini-Cat®, VGA over CAT5 Sender (local)</p>	
<p><b>UV1-S-WP</b> Mini-Cat®, VGA over CAT5 Sender (local) ) in a Single gang Wall Plate</p>	
<p><b>UV1-SL</b> Mini-Cat®, VGA over CAT5 Sender (local) with Loop-Thru VGA Port for Local Monitor Connection. Includes a Universal power supply. Can power Receiver via Cat5.</p>	
<p><b>UV2-S</b> 2-Channel VGA-to-CAT5 sender/splitter. Provides two RJ45 outputs plus a local VGA loop-thru. Comes with a universal power supply for the entire setup (can power 2 receivers via UTP)</p>	
<p><b>UV4-S</b> 4-Channel VGA-to-CAT5 sender/splitter. Provides 4 RJ45 outputs plus a local VGA loop-thru. Comes with a universal power supply for the entire setup (can power 4 receivers via UTP)</p>	
<p><b>UV8-S</b> 8-Channel VGA-to-CAT5 sender/splitter. Provides 8 RJ45 outputs plus a local VGA loop-thru. Comes with a universal power supply for the entire setup (can power 8 receivers via UTP)</p>	
<p><b>UV1-R</b> Mini-Cat®, VGA over CAT5 Receiver (remote)</p>	
<p><b>UV1-R-WP</b> Mini-Cat®, VGA over CAT5 Receiver (remote) in a Single gang Wall Plate</p>	

Manual #: UMA1074 Rev. 1 September 1, 2006



Hall Research Technologies, Inc  
1163 Warner Ave. Tustin, CA 92780



## Table of Contents

1.0	General Description .....	2
2.0	Features .....	3
3.0	Setup and Operation.....	4
3.1	Important note regarding selecting the UTP Cable .....	6
3.2	Dip Switch Settings for the Model UV1-SL.....	7
4.0	Specifications.....	8

## 1.0 General Description

This User's Manual covers the *Mini-Cat*® series of high-resolution PC or HDTV component video transmission system.

The transmission systems are comprised of one Sender unit and one or more Receiver units. They enable you to split and extend a PC VGA video or analog Component HDTV signal to 500 feet and beyond. The Model UV1-SL is *also* capable of extending a Composite Video & Stereo Audio to 2000 feet.

A unique feature of the system is that in most installations only one power supply is enough to power the sender and the receiver(s).

All sender units can supply power to all the receivers connected to them via the Cat5 cable. If the cable is longer than 325 feet or 100 m then the receiver may require a separate supply. Conversely, in the case of 1-to-1 setups, the Receiver unit can also supply power to the Sender (only when the Sender is a single channel).

The characteristics of the Sender units are summarized below:

Feature	UV1-S	UV1-S-WP	UV1-SL	UV2-S	UV4-S	UV8-S
Local VGA Loop out	No	Yes	Yes	Yes	Yes	Yes
# of RJ45 Outputs	1	1	1	2	4	8
Sends Power over UTP	Yes	Yes	Yes	Yes	Yes	Yes
Mounts on Wall	No	Yes	No	No	No	No

Table 1 – Sender Characteristics

Note: For Cat-5 runs of over 330 feet, the receivers may need their own additional supplies sold separately (HRT model # 511-GS569).

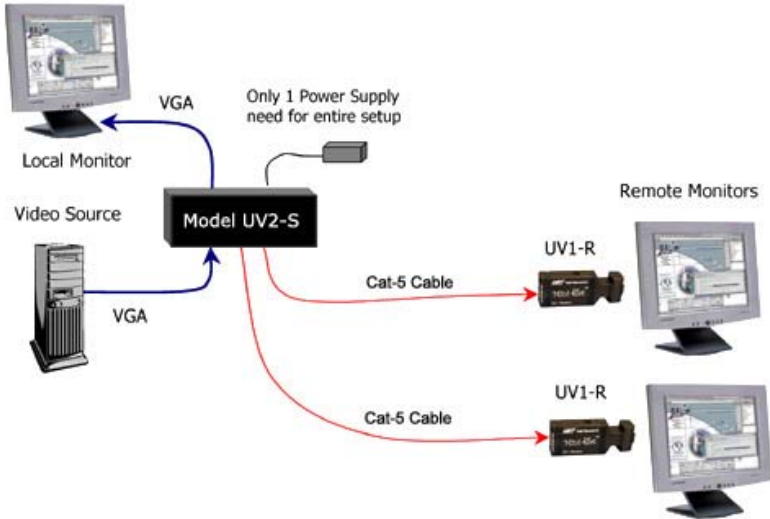

Figure 1 – Typical Connection Diagram

## 2.0 Features

- Most support local monitor at sending end
- Units with multiple Cat-5 outputs
- Handles resolutions up to 1600x1280
- Drives standard CAT5 cables to 500 feet
- Rugged, Reliable, Compact size
- Transmit video and phantom power on one cable
- Adjustable cable length compensation at each receiver
- Only one power supply required for sender and all receivers

## VGA-over-UTP

### 3.0 Setup and Operation

**A.** Place the sender near the video source and connect it to your source using the cable provided.

- For PC's VGA output use a HD15 male-to-male cable (generally a short cable may be included with your package)
- For RGB or YPbPr sources, use a HD15 to 3 RCA cable (Hall Research Model # CHD15-3RCA-length 03 = 3ft, 06 = 6 ft).

**B.** Use an Unshielded Twisted Pair (UTP) or a Shielded Twisted pair (STP) cable such as Cat5, 5e, or 6 wired per standard 568B to connect the sender to the receiver(s). See Section 3.1 for important cable selection considerations.

#### IMPORTANT

Do not connect this unit to any LAN device such as network cards or hubs as this may cause damage. Use EIA/TIA 568B standard straight-through patch wiring as shown below. Do not use crossover cables.

EIA/TIA 568B WIRING STANDARD	
PIN	Wire Color
1	White w/ Orange Stripe
2	Orange
3	White w/Green Stripe
4	Blue
5	White w/Blue Stripe
6	Green
7	White w/Brown Stripe
8	Brown

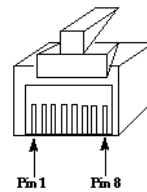

Figure 2

**C.** At each remote site connect a receiver (UV1-R and UV1-R-WP) to the Cat5 cable and plug your display to its HD15 output connector.

**D.** Plug a power supply to the System based on the type of the sender used.

In general, you should connect the power supply to the Sender unit. However, follow these suggestions for best performance.

- If the sender has more than one RJ45 output (UV2-S, UV4-S, UV8-S), then the power supply must be connected to the sender.
- If the Sender is a Model UV1-S, UV1-SL, or UV1-S-WP, where the system is comprised of only one sender and one receiver, then you can plug the power supply at either the sender or the receiver. In this case, it is recommended to plug the power supply at the Receiver. This is due to the fact that the Receiver usually consumes more power than the sender and connecting the supply to the receiver allows for a longer Cat5 run to be utilized.

**D1.** The wall plate units, UV1-S-WP and UV1-R-WP have a 2 pin screw connector for the connection of the power supply. The power supply output cord does not have a connector at its end; instead, it is stripped and tinned. The positive side has a white line running along the insulation of the cable.

The connection is polarized, meaning the you must connect the + output wire to the + screw terminal and – to –. The units are reverse polarity protected so if you inadvertently connect the wires, backwards, they will not get damaged.

You can use 18 gage or heavier wire to extend the DC output cord of the power supply if you need to locate the power supply farther from the device. It is recommended to keep the distance of the supply from the unit to within 30 feet.

**Note:** Please do not connect the power supply to the AC source until you have securely connected the output cords to the Wall Plate Mini-Cat unit.

**E.** Apply a video source to the system and check for an image at each receiver, then set the compensation Potentiometer (pot) for best possible image.

## VGA-over-UTP

Start with the compensation pot fully CCW (least compensation), then slowly turn it clockwise and check for the bleeding of left to right horizontal lines on the screen.

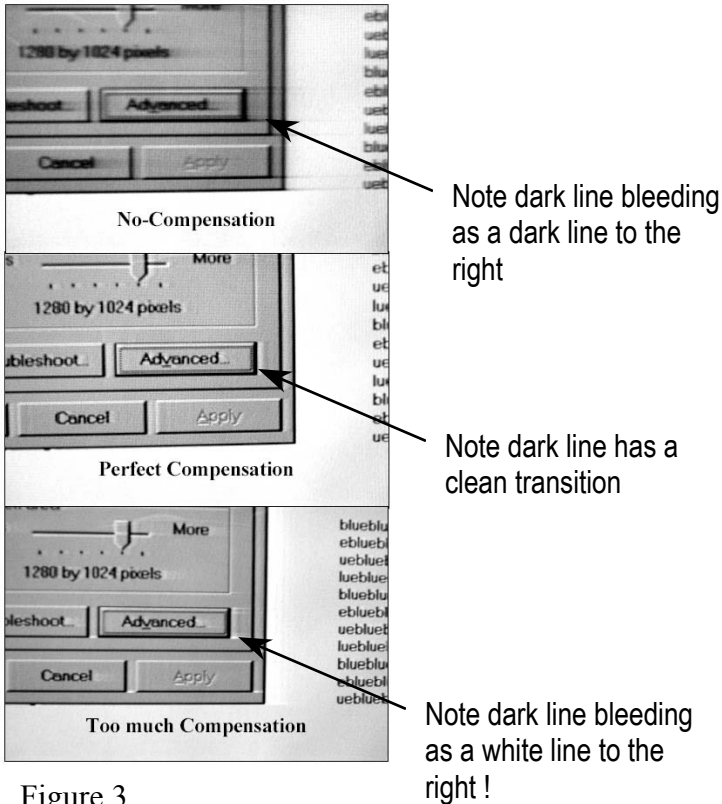

Figure 3

### 3.1 Important note regarding selecting the UTP Cable

First of all, UTP (unshielded) is preferred over STP (shielded) unless you are running the cable very close to AC power lines, power transformers, or ballasts of fluorescent lights, where EMI (electromagnetic interference) can get into the video if it is strong enough.

Secondly, for best results especially for distances of over 150 feet, it is highly recommended to use a Zero-Skew Cat5 cable. (Hall Research Part Number CUTP-Z-1000). This cable ensures that the horizontal alignment of the red, green, and blue components of the

video signal is maintained regardless of the length of the Cat5 cable. In this cable, the number of twists in each of the 4 pairs in the cable are the same. If you do not use a Zero Skew cable and feel that the RGB alignment is off by an unacceptable level, then you can use a Skew Corrector (Hall Research Model SKU-RGB) at the display device if desired)

- For Cat5 runs of over 330 ft, you may need to connect a power supply to the sender as well as the receiver. This is due to the fact that the resistance of the cable causes a voltage drop from the sender to the receiver and the voltage level of the power at the receiver may not be sufficient for proper operation. This extra power supply must be ordered separately (Model 511-GS569).
- When using one supply for the system, if the power supply voltage is not enough due to Cat5 cable run, then, the power LED on some units may start blinking. This signifies that you need to attach another power supply to the unit that is currently being port powered

### 3.2 Dip Switch Settings for the Model UV1-SL

The UV1-SL can be used to transmit Composite Video and Stereo Audio as well as VGA to the receiver. However since the Video signals are terminated differently than audio, you need to move the dip switch to the proper position.

Use the Mode Dip Switch to select the video type for transmission.

The Sync Dip Switch is used to change the polarity of

sync at the receiver. If your remote display has trouble positioning the right and left edges of the screen, then try putting the switch is +/-

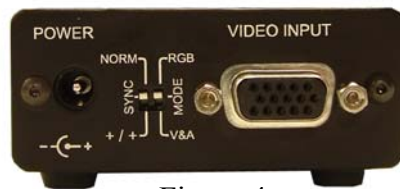

Figure 4

## 4.0 Specifications

### Supported

**Video Types:** VGA through UXGA, RGB, and YPbPr,  
plus CV and line level stereo audio for UV1-SL

### Resolution &

**Refresh Rate** Up to 1600 x 1280 non-interlaced at up to 85 Hz

**Bandwidth** DC to 250 MHz

### Maximum

**Distance** Up to 500 ft. (152 meters)

**Connectors** HD15 female for video input and output  
RJ45 for CAT5 outputs

**Compliance** CE; FCC Part 15 Subpart B Class A, IC Class

**Power** From utility-power (mains) outlet, through included external Universal power supply. Output Voltage: 9 DC Center-Positive,  
*Do not substitute any other external power supply without contacting the factory first*

**Size** UV1-S: 0.8" H X 1.7" W X 4.5" L  
UV1-SL: 1.1" H X 2.75" W X 3.1" L  
UV2-S : 1.22" H x 4.86"W x 2.60"D  
UV4-S : 1.22" H x 8.20" W x 3.00" D  
UV8-S : 1.32" H x 7.58" W x 3.88" D  
*(UV8-S has 2 L-shaped mounting ears that protrude 0.88" beyond the main box on each side. 4 mounting holes are present on a rectangular pattern of 8.62" x 2.63")*  
UV1-R: 0.8" H X 1.7" W X 4.5" L





Products Designed and Made in the USA



© Copyright 2006. Hall Research Technologies, Inc.. All rights

1163 Warner Ave., Tustin, CA 92780 Ph: (714) 641-6607, Fax: (714) 641-6698